

Call for Artists

Outdoor Sculpture Loan Competition

Burnsville, North Carolina

Deadline 5pm May 27, 2011

Contact: Toe River Arts Council trac@toeriverarts.org or 828-682-7215

You are invited to submit your work for the Town of Burnsville's first outdoor sculpture competition. The site is the planted area at the northeast corner of the Town Center on South Main Street.

The newly designated Mount Mitchell Scenic Drive leads visitors from the Blue Ridge Parkway and the highest peak east of the Mississippi through this bustling, picturesque small town with its classic, tree-lined Town Square. In addition to its natural beauty and Southern Appalachian heritage, the surrounding area boasts one of the highest concentrations of artists and craftspeople anywhere in the United States. The sculpture selected through this competition will be seen by many of the visitors who enjoy Toe River Arts Council's semi-annual Studio Tour and the 40,000 who attend the annual Mt. Mitchell Crafts Fair in Burnsville. It will join a growing number of public art pieces on South Main Street.

Deadline: Entries received by 5pm Friday, May 27, 2011

Notification: Friday, June 3, 2011

Installation: Friday, June 24, 2011

Public Art Celebration: Event date and details to be announced; the selected artist is invited.

Loan Period: Approximately eleven months

Artist Eligibility: Any artist may enter.

Entry Fee: None

Honorarium: \$250, payable after installation

Sales: Sales are encouraged. Toe River Arts Council will handle sales through its nearby gallery with a 30% commission. Sold work may be removed immediately at the artist's option, or is welcome to remain for the scheduled time. Not-For-Sale works are also welcome.

Insurance is NOT provided by the Town: The Town shall not be liable for damages to the art or injuries arising from its existence on Town property.

Site and Installation Details: See page 3 for site details. The Town of Burnsville may be able to provide reasonable assistance with installation, including pouring a concrete pad if needed.

Eligible Works: Existing three-dimensional work in any durable medium suitable for all-weather display at the designated site is eligible. Public safety considerations include:

- A. No works of art may protrude into South Main Street or into any sidewalk.
- B. All works of art will be affixed to the ground by means of sufficient sized base or other means to ensure it does not overturn easily.
- C. No works of art will be permitted to block the view of any traffic on South Main Street nor will it be permitted to block the view or entrance to any building or business.

The Burnsville Public Art Policy encourages placement of works of art that "interpret the unique cultural, historical, natural, and human resources of our community while enhancing the built or natural environment." While many competitions restrict entries to works completed in the last two or three years, this competition specifically invites artists to submit either recent work or favorite past work they would like to share with the public in this setting.

Selection criteria: Submitted works will be considered on artistic merit, appropriateness for the site, public safety, and durability. The Burnsville Public Art Design Board may choose to select one additional work for display nearby on South Main Street, or may choose to select no works if selection criteria are not met.

next page: Entry Procedure

Entry Procedure:

If you need assistance with the entry process, please contact Toe River Arts Council at trac@toeriverarts.org or 828-682-7215.

Sculptors may submit up to three completed works. Work-in-progress or proposals will not be considered.

Digital images should be submitted on CD/DVD:

1. Images: Sculptors may submit **up to three images of each work**, for a maximum of nine images.

- Images must be individual JPEG/JPG files. Images embedded in a document such as PDF or PowerPoint will not be considered. Videos will not be considered. Full camera resolution is best; suggested minimum resolution is 800x600 pixels.
- Images may be in any orientation and may be cropped; excessive image manipulation is discouraged.
- The preferred style for naming the image files is **Lastname Title 1.jpg** (see example below). You are not required to follow this style, so long as the identification is clear.

Other entry materials may be on paper or may be on the CD in a single document or separate plain text (TXT), Rich Text Format (RTF), Word (DOC, DOCX), or PDF files:

2. Contact information - name, address, phone(s), email, website - and **image list (see example below)**, showing the title, dimensions, material, retail price (or NFS) of each submitted work, keyed to the image file names. Add any installation considerations.

3. Short résumé or biographical information.

4. Artist statement (optional).

All submitted materials will be retained unless a self-addressed stamped envelope is enclosed or other arrangements are made.

The Town of Burnsville and Toe River Arts Council reserve the right to photograph or videotape the selected work for publicity, grant writing, and promotional purposes. Your entry constitutes understanding and agreement with the conditions outlined in this Call for Artists.

Entries must be received at the Toe River Arts Council gallery/office in Burnsville by 5pm Friday, May 27:

US Postal Service: Toe River Arts Council, PO Box 882, Burnsville NC 28714

Parcel services and hand delivery: Toe River Arts Council, 102 West Main St, Burnsville, NC 28714

Image list example:

(This example uses a short title in the image file name, keyed to the full title in the image list.)

Frame of Reference

96" tall x 42" wide x 32" deep

steel

\$2,400

Smith Frame 1.jpg

Smith Frame 2.jpg

Smith Frame 3.jpg

I need access for a 10-foot trailer and full-size pickup. Weight is about 1,000 pounds. A 48"x48" concrete pad will be perfect for installation. I will do some on-site assembly (bolting) – about 2 hours.

The intent of the Burnsville Public Art Policy is to direct the inclusion of public art in order to expand each citizen's experience with art and enable them to better understand their community. By encouraging artists capable of creating works of art in public places, the policy shall strive to stimulate the vitality and economy of the town. It is the goal of the Public Art Policy to facilitate installation of works of art and art projects of redeeming quality which advance public understanding of visual art.

Toe River Arts Council, a nonprofit organization, helps implement the Public Art Policy of the Town of Burnsville in a variety of ways, including serving as the contact point for artists.

www.toeriverarts.org

Site Details

Outdoor Sculpture Loan Competition Burnsville, North Carolina Deadline 5pm May 27, 2011

Contact: Toe River Arts Council trac@toeriverarts.org or 828-682-7215

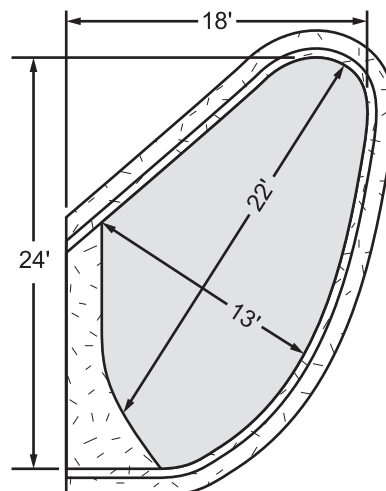

Gray area in drawing indicates current mulched area within concrete curb. Town staff plans to remove existing tree. Selected artist can discuss removal or adjustment of other landscaping elements, including shrubs, with Town staff.

Dimensions are approximate. Not to scale.